

## 1 STANDARDS & CONDITIONS

### DESIGN STANDARDS

The designs and the productions are in conformity with:

- Conformance Européenne (CE)
- ISO8528-5:2005
- AS 3000-2018
- AS 3010-2017

### ENVIRONMENTAL OPERATING CONDITIONS

- Installation place: Outdoors or indoors (well ventilated).
- Ambient temperature: -25°C to 45°C. The coolant heater is needed when the temperature is below 5°C
- Humidity: Less than 90%.
- Altitude: Below one thousand (1000) meters above sea level.

### FACTORY INSPECTION

- Inspection items.
- Protection devices working test.
- Starting ability in normal temperature.
- 50% rated power load moment capability.
- Voltage deviation and speed variation: 0%, 25%, 50%, 75%, 100%, 110% Load.

### PAINTING PROCESS

- Painting process specifications and colors are based on the manufacturer's standard.
- The customer could also choose the color which the manufacturer offers.

## 2 GENERAL FEATURES

- Powerlink engine VR6-10TAG1
- Close coupled to Power alternator PL3H
- Microprocessor control module PLC-920
- Main circuit breaker: 400A
- Rotate speed governor: Mechanical governor
- Excitation System: Self Excited, SHUNT
- A.V.R. Model: SX440
- Key switch
- Emergency stop switch
- ATS (automatic transfer switch) receptacle
- Remote run connector

- 2x12V/120AH sealed for life maintenance free battery
- Lockable battery isolator switch
- Powder coated canopy
- 50°C radiator
- Oil pump on the engine
- Steel base frame with forklifts
- Vibration isolators between the engine/alternator and base frame
- Dry type air filter
- Base fuel tank with 17 hours running
- Drain points for fuel tank
- Operator's Manual / Specifications

## 3 EQUIPMENT SPECIFICATION

### GENERAL TECHNICAL DATA

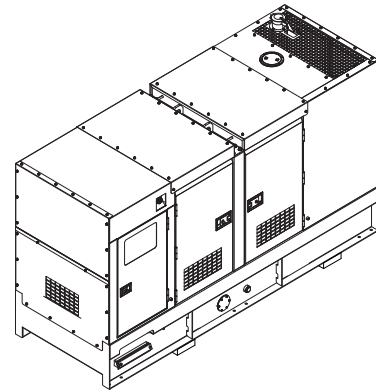

Model.....	VR250XS-AU
Tank capacity.....	920L
Dry weight.....	3800kg
Noise level @7m.....	72.0dBA
Dimensions L×W×H.....	3850x1450x2260mm
Standby Power.....	275kVA/220kW
Prime Power.....	250kVA/200kW

Voltage	380V	400V	415V		
Ampere	379.8A	360.9A	347.8A		
<b>Genset Fuel Consumption</b>					
Frequency/Load	25%	50%	75%	100%	110%
50Hz (L/h)	15	28	40	54	60

## POWER SYSTEM

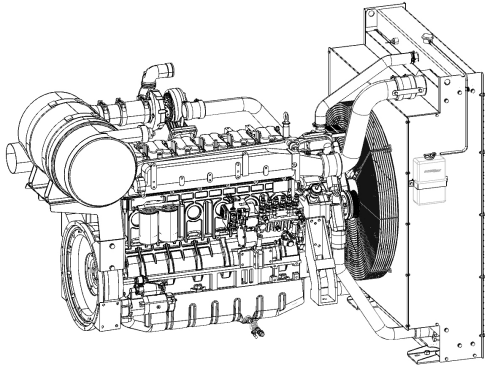

Engine Manufacturer/Brand.....	Powerlink
Engine Model.....	VR6-10TAG1
Dimensions L×W×H.....	1796×767×1275mm
Dry Weigh (approx.) .....	1000kg
Number of Cylinders.....	6
Bore.....	126mm
Stroke.....	130mm
Displacement.....	10.0L
Compression Ratio.....	17.0
Type of injection.....	Direct injection
Intake System.....	Turbocharged and charge air cooled
Intake Resistance .....	≤ 5kPa
Cooling System .....	Water cooled
Fan .....	Pusher
Battery Voltage .....	24V
Type of Fuel.....	No.2 or ASTM D975
Type of Oil .....	API CF/SE or CCMCF4
Oil Capacity .....	23.0L
Type of Coolant .....	Glycol mixture
Coolant Capacity .....	25.0L
Back Pressure.....	≤ 10.1kPa
Standby Power .....	253kW
Prime Power .....	230kW

## ALTERNATOR

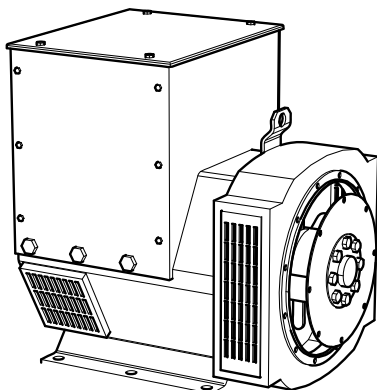

Alternator Manufacturer/Brand.....	Powerlink
Alternator Model .....	PL3H
Exciter.....	Brushless
Cooling Fan.....	Cast alloy aluminum
Windings.....	100% copper
Insulation Class .....	H
Winding Pitch.....	2/3
Terminals .....	12
Drip Proof .....	IP23
Altitude.....	≤1000m
Overspeed .....	2250rpm
Air Flow.....	N/A
Voltage Regulation .....	±1.0%
Total Harmonic TGH / THCat no load < 1.5 % - on load < 5%	
Telephone Interference.....	THF<2%;TIF<50

## DSE4520 CONTROL SYSTEM



The DSW4520 is a compact Auto Mains (Utility) Failure Control Module that have been developed to provide an outstanding range of features within a compact enclosure.

### Product highlights:

- Large back-lit icon LCD display.
- Heated display option.
- 3-phase generator sensing.
- 3-phase generator and mains (utility) sensing.
- 600 V ph-ph nominal system compatibility.
- Generator & load power monitoring (kW, kVA, Kv Ar, pf).
- Generator overload protection (kW).
- Configurable inputs & outputs.
- Battery voltage monitoring.
- CAN & alternator speed sensing.
- Engine speed protection, engine hours counter, engine pre-heat, engine run-time scheduler, engine idle control for start/stop.

## 4 OVERALL DIMENSIONS

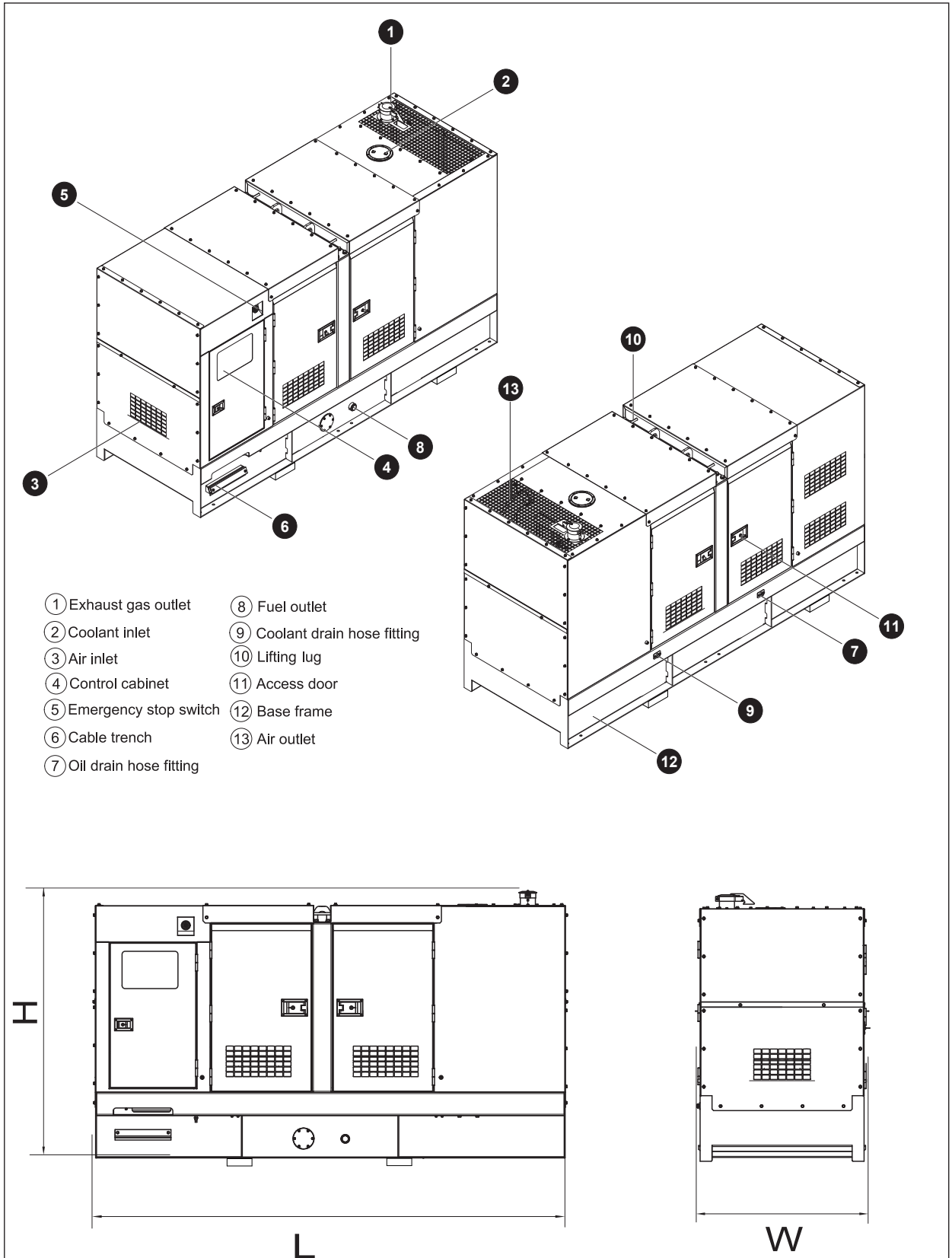

## 5 CONTROL SYSTEM

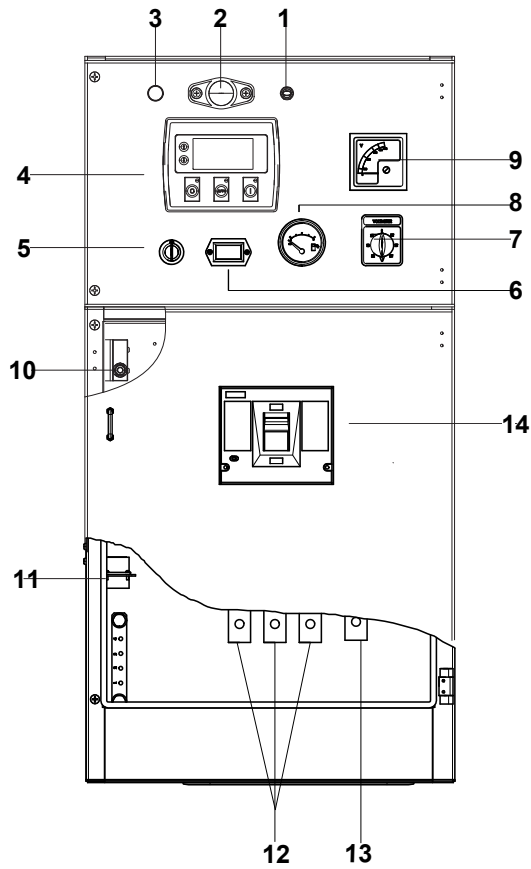

**Control & field wiring cabinet**

Ref.	Description
1	Control cabinet lamp switch
2	Control cabinet lamp
3	Charge indicator
4	Control module
5	Key switch
6	Time counter
7	Voltage changer-over switch
8	Fuel level meter
9	Voltage meter
10	Limit switch
11	Mains input/Remote control/ATS connector
12	Live wire terminal
13	Neutral wire terminal
14	Main circuit breaker

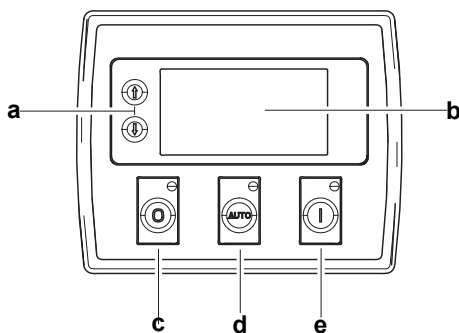

**Control module**

Ref.	Description
a	Navigation button«» Accept (Configuration mode only)
b	Main status display
c	Stop/reset button«» Next page (Configuration mode only)
d	Auto start button«» Decrease value/next item (Configuration mode only)
e	Start button«» Increase value/next item (Configuration mode only)