

1 STANDARDS & CONDITIONS

DESIGN STANDARDS

The designs and the productions are in conformity with:

- Conformance Européenne (CE)
- ISO8528-5:2005
- AS 3000-2018
- AS 3010-2017

ENVIRONMENTAL OPERATING CONDITIONS

- Installation place: Outdoors or indoors (well ventilated).
- Ambient temperature: -25°C to 45°C. The coolant heater is needed when the temperature is below 5°C
- Humidity: Less than 90%.
- Altitude: Below one thousand (1000) meters above sea level.

FACTORY INSPECTION

- Inspection items.
- Protection devices working test.
- Starting ability in normal temperature.
- 50% rated power load moment capability.
- Voltage deviation and speed variation: 0%, 25%, 50%, 75%, 100%, 110% Load.

PAINTING PROCESS

- Painting process specifications and colors are based on the manufacturer's standard.
- The customer could also choose the color which the manufacturer offers.

2 GENERAL FEATURES

- Powerlink engine VR6-35TAG4
- Close coupled to Power alternator PL6B
- Microprocessor control module XC762
- Main circuit breaker: 1600A
- Rotate speed governor: Mechanical governor
- Excitation System: Self Excited, SHUNT
- A.V.R. Model: SX440
- Key switch
- Emergency stop switch
- ATS (automatic transfer switch) receptacle
- Remote run connector

- 2x12V/150AH sealed for life maintenance free battery
- Lockable battery isolator switch
- Powder coated canopy
- 50°C radiator
- Oil pump on the engine
- Steel base frame with forklots
- Vibration isolators between the engine/alternator and base frame
- Dry type air filter
- Base fuel tank with 7 hours running
- Drain points for fuel tank
- Operator's Manual / Specifications

3 EQUIPMENT SPECIFICATION

GENERAL TECHNICAL DATA

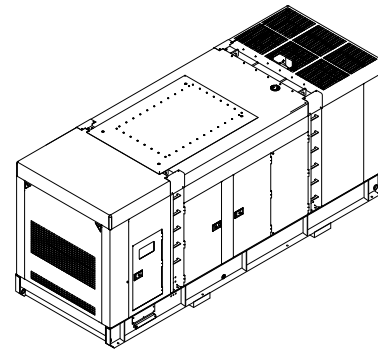

Model..... VR900XS-AU
 Tank capacity.....1600L
 Dry weight.....7800kg
 Sound pressure level @ 7m.....77.0dBA
 Dimensions L×W×H.....4695x1725x2557mm
 Standby Power1000kVA/800kW
 Prime Power900kVA/720kW

Voltage	380V	400V	415V		
Ampere	1367.4A	1299.1A	1252.1A		
Genset Fuel Consumption					
Frequency/Load	25%	50%	75%	100%	110%
50Hz (L/h)	57	112	160	220	243

POWER SYSTEM

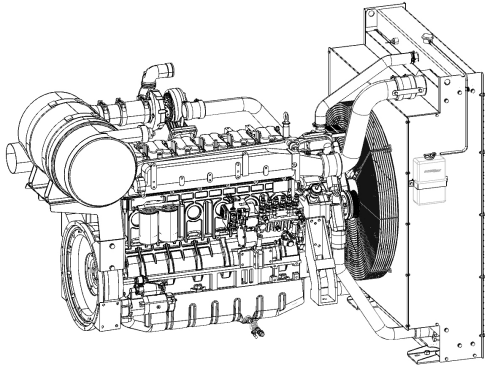

Engine Manufacturer/Brand.....	Powerlink
Engine Model.....	VR6-35TAG4
Dimensions L×W×H.....	2429x1387x2146mm
Dry Weigh (approx.)	4000kg
Number of Cylinders.....	6
Bore.....	186mm
Stroke.....	215mm
Displacement.....	35.0L
Compression Ratio.....	15.0
Type of injection.....	Direct injection
Intake System.....	Turbocharged and charge air cooled
Intake Resistance	≤ 5kPa
Cooling System	Water cooled
Fan	Pusher
Battery Voltage	24V
Type of Fuel.....	No.2 or ASTM D975
Type of Oil	API CF/SE or CCMCF4
Oil Capacity	80.0L
Type of Coolant	Glycol mixture
Coolant Capacity	90.0L
Back Pressure.....	≤ 10.1kPa
Standby Power	900kW
Prime Power	818kW

ALTERNATOR

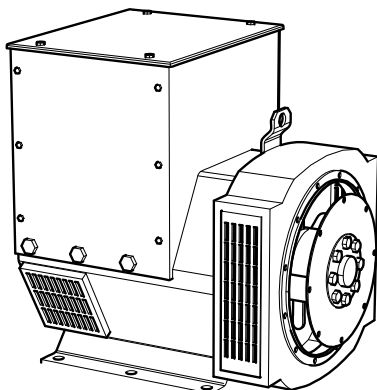

Alternator Manufacturer/Brand	Powerlink
Alternator Model	PL6B
Exciter.....	Brushless
Cooling Fan.....	Cast alloy aluminum
Windings.....	100% copper
Insulation Class	H
Winding Pitch.....	2/3
Terminals	12
Drip Proof	IP23
Altitude.....	≤1000m
Overspeed	2250rpm
Air Flow.....	N/A
Voltage Regulation	±1.0%
Total Harmonic TGH / THCat no load < 1.5 % - on load < 5%	
Telephone Interference.....	THF<2%;TIF<50

DEESEA 7420 CONTROL SYSTEM



The DSE7420 is a sophisticated mono display auto mains (utility) control module packed with industry leading features to enhance single-set control. The module can be used across a wide range of diesel and gas gen-set applications.

Product highlights:

- CAN and magnetic pick-up sensing.
- Configurable inputs/outputs (11/8).
- Fuel usage monitor and low level alarms.
- Remote communications (RS232, RS485, Ethernet, Modbus, RTU/TCP).
- Configurable event log (250).
- Integral PLC editor.
- Power monitoring (kW h, kVAh, kv Ah, kV Ar h), reverse power protection, kW overload protection.
- Load switching, load shedding & dummy load outputs.
- Data logging (USB Memory Stick).
- DSE Configuration Suite PC Software.
- Tier 4 CAN engine support.

4 OVERALL DIMENSIONS

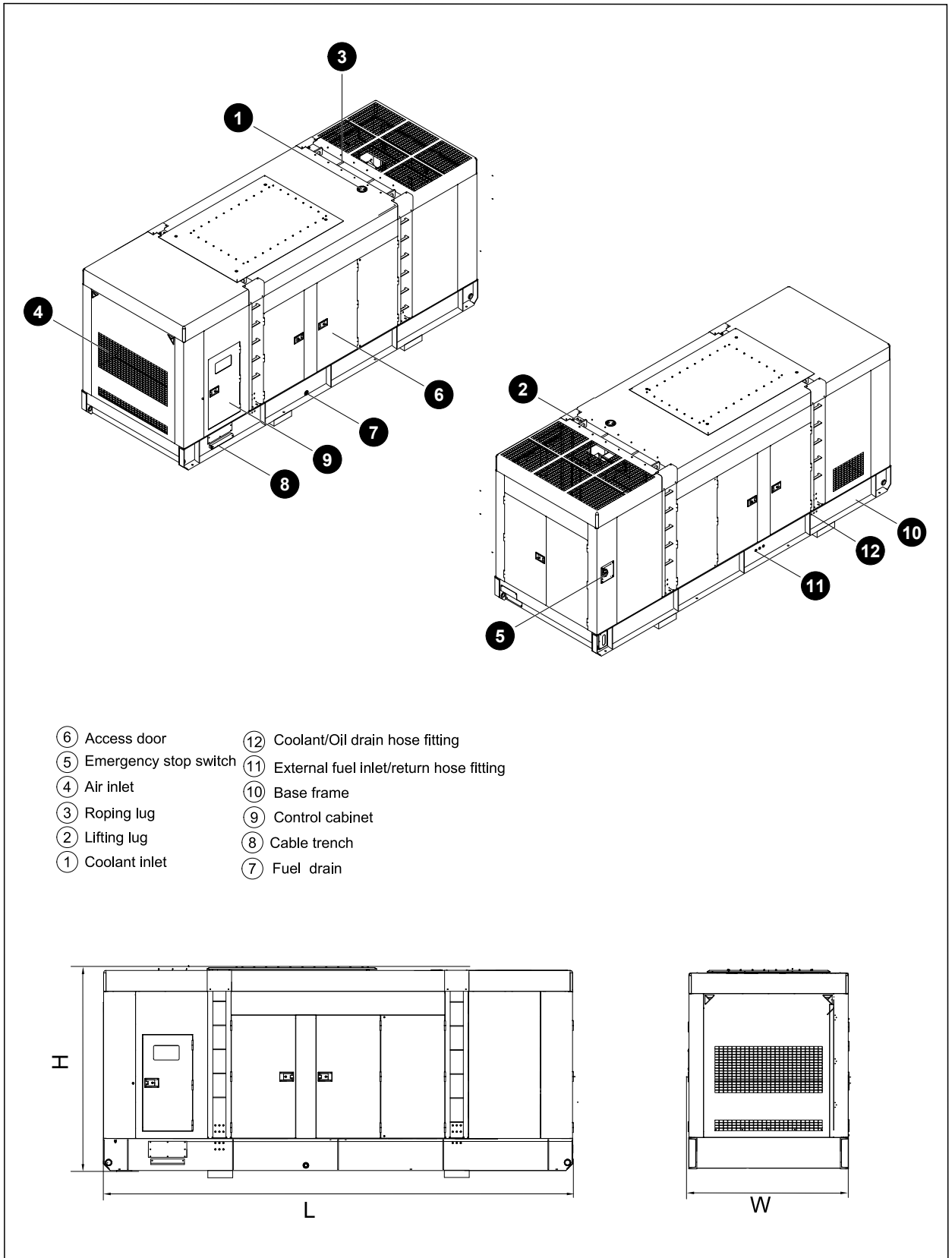

5 CONTROL SYSTEM

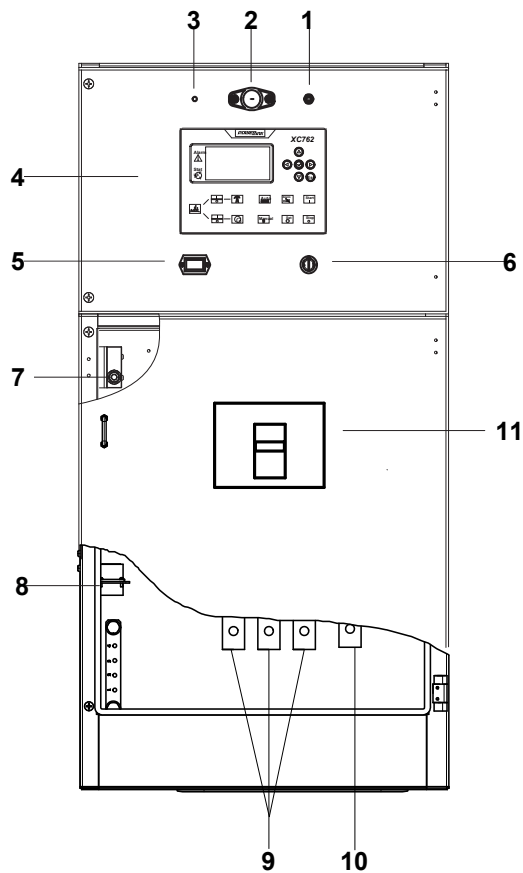

Control & field wiring cabinet

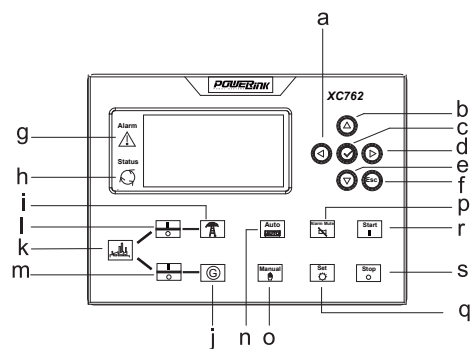

Control module

Ref.	Description
1	Control cabinet lamp switch
2	Control cabinet lamp
3	Charge indicator
4	Control module
5	Time counter
6	Key switch
7	Limit switch
8	Mains input/Remote control/ATS connector
9	Live wire terminal
10	Neutral wire terminal
11	Main circuit breaker

a	Button (next page)
b	Button (increase value / previous item)
c	Button (accept)
d	Button (previous page)
e	Button (decrease value / next item)
f	Button (ESC)
g	Indicator (alarm)
h	Indicator (running)
i	Indicator (mains available)
j	Indicator (genset available)
k	Indicator (mains / genset ON)
l	Button (breaker ON / OFF)
m	Button (breaker ON / OFF)
n	Button (Auto mode)
o	Button (Manual mode)
p	Button (reset alarm)
q	Button (set parameters)
r	Button (start)
s	Button (stop)